

# BULL 20HE BULL 20HEA

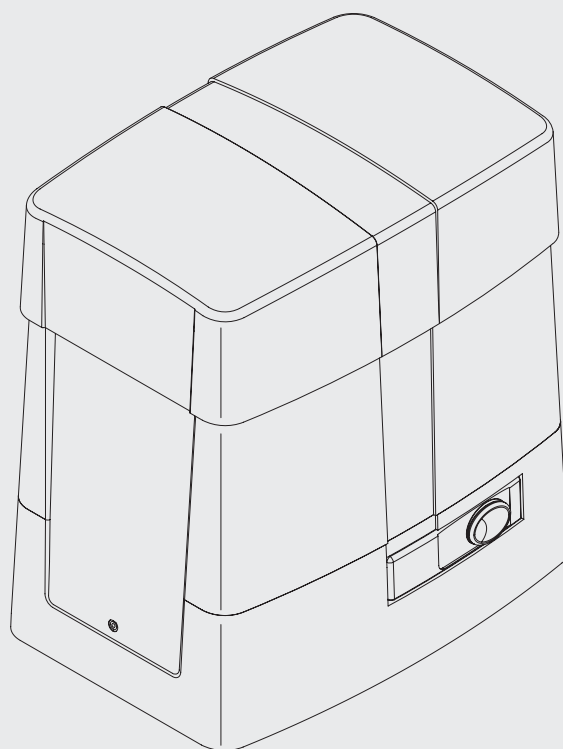

**BENINCA**<sup>®</sup>  
TECHNOLOGY TO OPEN



Dati tecnici	Technical data	Technische Daten	BULL 20HE	BULL 20HEA
Alimentazione	Feed	Speisung	230 Vac 50 Hz	120 Vac 60 Hz
Assorbimento	Absorption	Verbrauch	3 A	6 A
Coppia	Torque	Kräftepaar	40 Nm	40 Nm
Intermittenza di lavoro	Operating jogging	Betriebsintermittenz	80 %	80 %
Grado di protezione	Protection class	Schutzklasse	IP44	IP44
Temp. funzionamento	Working temperature	Betriebstemperatur	-20°C / +50°C	-20°C / +50°C
Peso max. cancello	Max. gate weight	Gittergewicht max.	2000kg	2000kg
Modulo cremagliera	Rack modulus	Modul der Zahnstange	M4	M4
Velocità apertura	Opening speed	Öffnungsgeschwindigkeit	10,5m/min	10,5m/min
Condensatore	Capacitor	Kondensator	25 µF	100 µF
Rumorosità	Noise level	Geräusentwicklung	<70 dB	<70 dB
Lubrificazione	Lubrication	Schmierung	Olio/Oil	Olio/Oil
Peso	Weight	Gewicht	21,4 Kg	21,9 Kg

Donnees technique	Datos técnicos	Dane techniczne	BULL 20HE	BULL 20HEA
Alimentation	Alimentación	Zasilanie	230 Vac 50 Hz	120 Vac 60 Hz
Absorption	Absorción	Pobór mocy	3 A	6 A
Couple	Par	Moment obrotowy	40 Nm	40 Nm
Intermittence de travail	Intermitencia de trabajo	Rodzaj pracy	80 %	80 %
Degré de protection	Grado de protección	Stopień ochrony	IP44	IP44
Temp. fonctionnement	Temp. funcionamiento	Temp. podczas pracy	-20°C / +50°C	-20°C / +50°C
Poids max. portail	Peso máx. de la cancela	Ciężar max. bramy	2000kg	2000kg
Module de la crémaillère	Módulo de cremallera	Typ listwy zębatej	M4	M4
Vitesse d'ouverture	Velocidad de apertura	Prędkość otwieraia	10,5m/min	10,5m/min
Condensateur	Condensador	Kondensator	25 µF	100 µF
Bruit	Ruido	Max. halas	<70 dB	<70 dB
Lubrification	Lubrificación	Smarowanie	Olio/Oil	Olio/Oil
Poids	Peso	Ciężar	21,4 Kg	21,9 Kg

**Dimensioni d'ingombro - Overall dimensions**  
**Abmessungen - Dimensions d'encombrement**  
**Dimensiones exteriores - Wymiary gabarytowe**

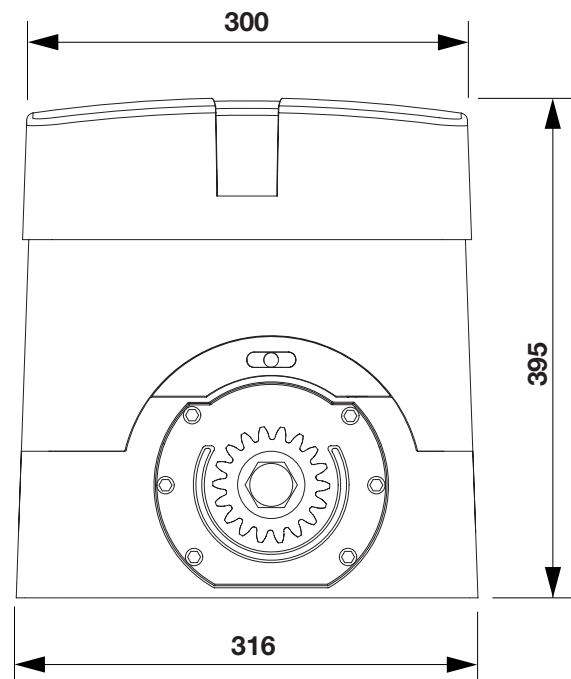
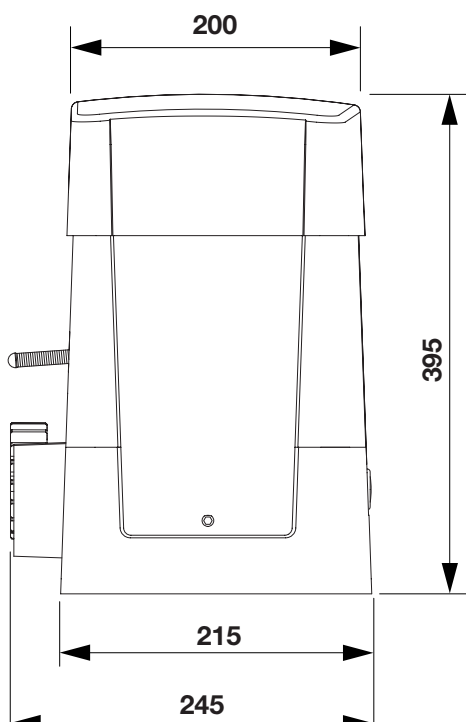

**IMPORTANTE:** Rispettare questa quota!  
**IMPORTANT NOTE:** Keep to this dimension!  
**WICHTIG:** Dieses Maß beachten!  
**IMPORTANT:** Respectez ce quota!  
**IMPORTANTE:** ¡Respetar esta cota!  
**WAŻNE:** Zachować ten wymiar!

Tubo corrugato  
**Grooved tube**  
 Faltenrohr  
**Passe-câbles tubulaire**  
 Tubo corrugado  
**Rurka sprężysta**

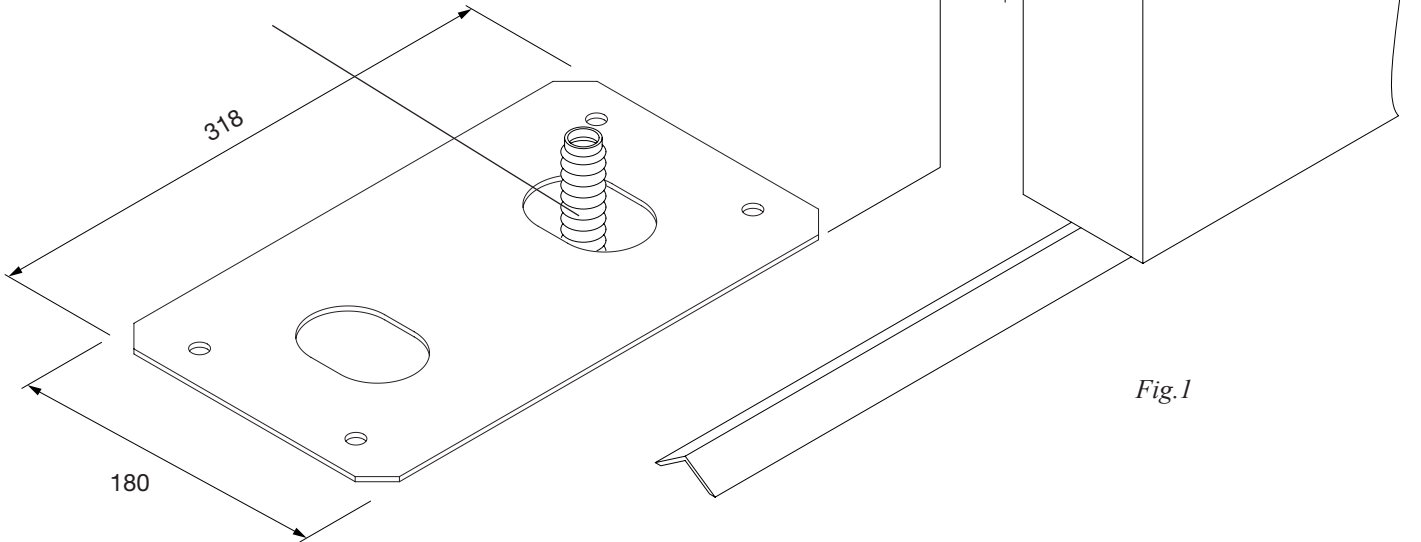
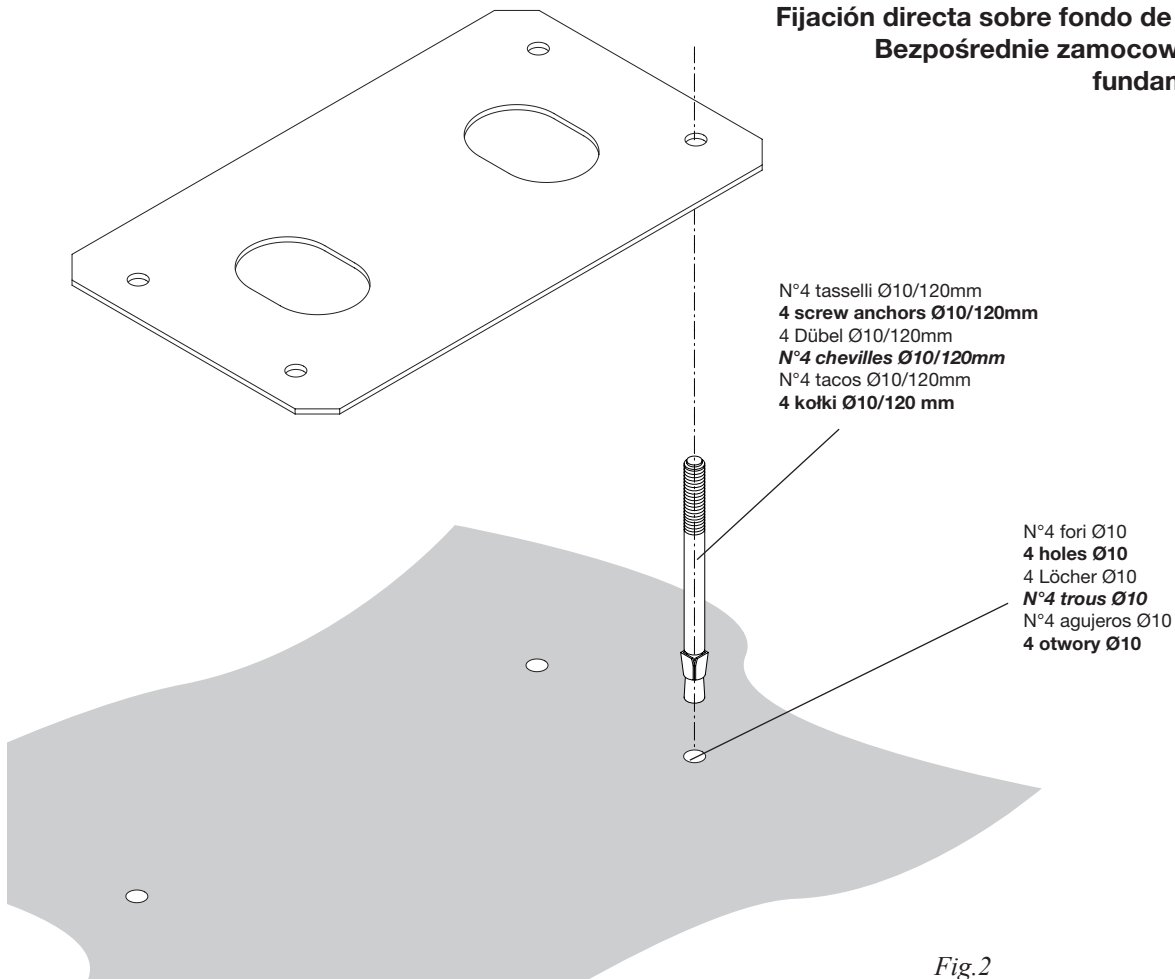

Fig.1

**Fissaggio diretto su fondo in cemento esistente**  
**Direct fitting on the already existing base in concrete**  
**Direkte Befestigung an einem vorhandenen Betonuntergrund**  
**Ancrage direct sur fond en ciment préexistant**  
**Fijación directa sobre fondo de cemento existente**  
**Bezpośrednie zamocowanie w istniejącym fundamencie betonowym**



N°4 tasselli Ø10/120mm  
**4 screw anchors Ø10/120mm**  
 4 Dübel Ø10/120mm  
**N°4 chevilles Ø10/120mm**  
 N°4 tacos Ø10/120mm  
**4 kołki Ø10/120 mm**

N°4 fori Ø10  
**4 holes Ø10**  
 4 Löcher Ø10  
**N°4 trous Ø10**  
 N°4 agujeros Ø10  
**4 otwory Ø10**

Fig.2

**Fissaggio con regolazione su fondo in cemento esistente**  
**Fitting with adjustment on the already existing base in concrete**  
**Befestigung an einem vorhandenen Betonuntergrund**  
**und Einstellung**

**Ancrage avec réglage sur fond en ciment préexistant**  
**Fijación con regulación sobre fondo de cemento**  
**existente**

**Zamocowanie z możliwością regulacji w**  
**istniejącym fundamencie betonowym**

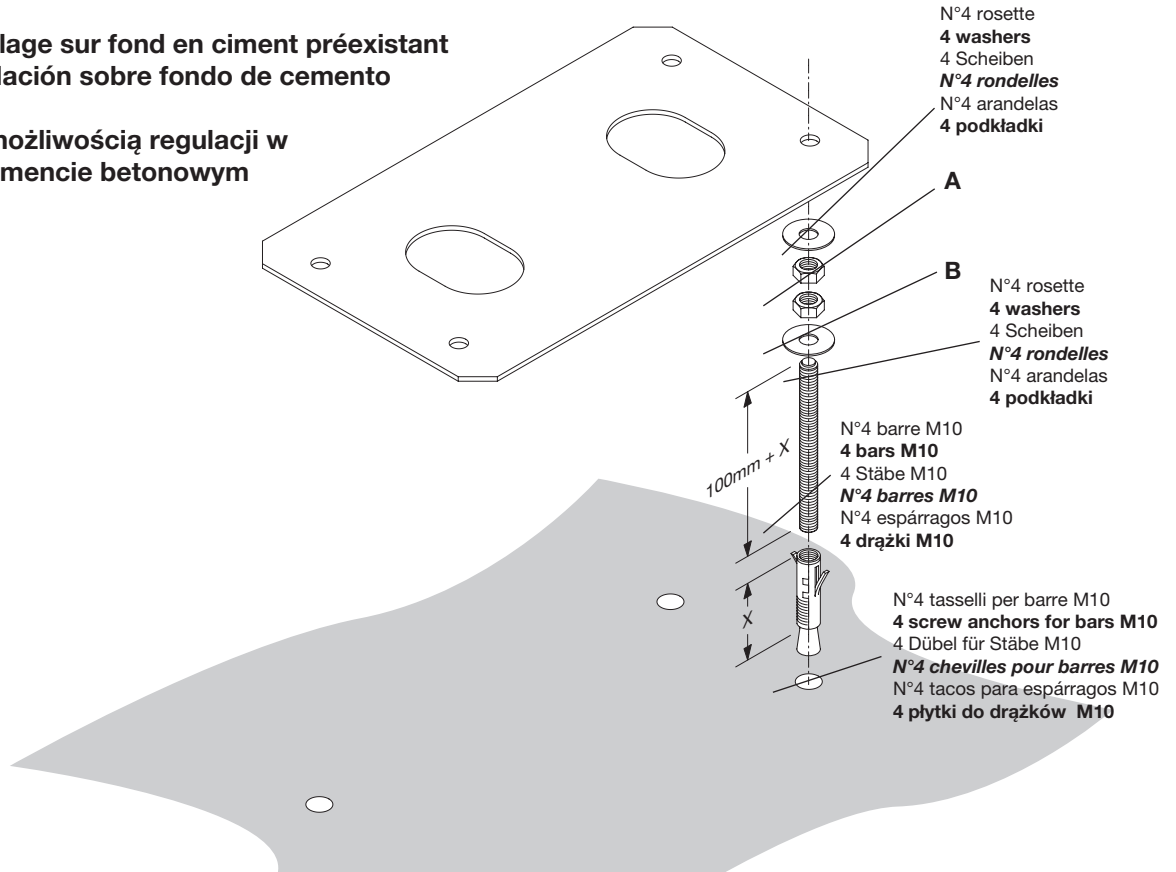
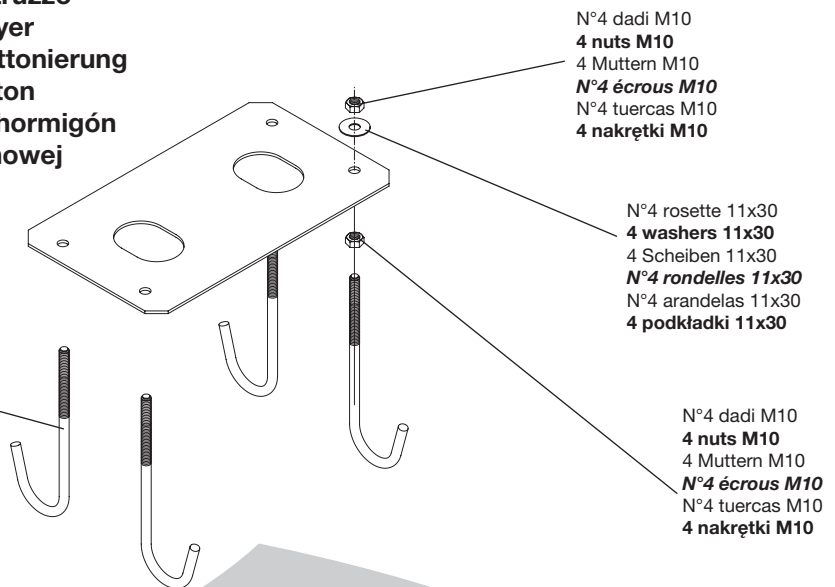

Fig.3

**Fissaggio con tirafondi su getto in calcestruzzo**  
**Fitting with stretcher bolts on concrete layer**  
**Befestigung durch Zugbolzen an einer Betonierung**

**Ancrage avec tire-fonds sur coulée de béton**  
**Fijación con tirafondos sobre vaciado de hormigón**  
**Zamocowanie z odciążem w płycie betonowej**

N°4 tirafondi filettati M10 annegati nel calcestruzzo  
**4 M10 threaded stretcher bolts immersed in concrete**  
 4 Zugbolzen mit Gewinde M10 im Beton eingebettet  
 N°4 tire-fonds filetés M10 noyés dans le béton  
 N°4 tirafondos con rosca M10 ahogados en el hormigón  
**4 odciążi gwintowane M10 zakotwiczone w betonie**



Scavo per getto di calcestruzzo  
**Hole for concrete layer**  
 Baugrube für Betonierung  
 Cavage pour coulée de béton  
 Excavación para vaciado de hormigón  
**Wykopy do wylania betonu**

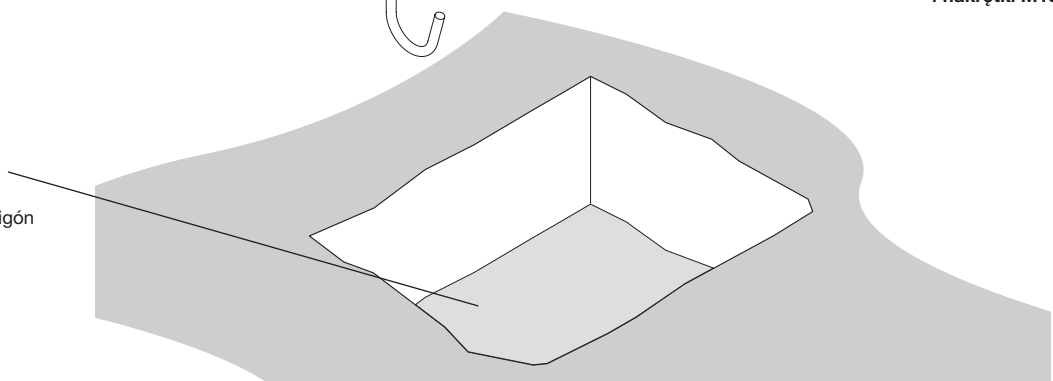

Fig.4

Attendere il consolidamento del getto di calcestruzzo, quindi rimuovere i dadi "D" e le rondelle "R" fascia larga 11x30 e portarli sotto la piastra per consentire le regolazioni in altezza dell'attuatore.

**Wait for hardening of the concrete layer, then remove the nuts "D" and the 11x30 large band washers "R", move them under the plate to allow for the actuator adjustment in height.**

Abwarten bis der Beton ausgehärtet ist, dann die Muttern „D“ und die breiten Scheiben „R“ 11x30 abnehmen und unter die Platte bringen, um die Höhe des Aktuators einstellen zu können.

**Attendez le durcissement de la coulée de béton et retirez les écrous "D" et les rondelles "R" bande large 11x30, peòrtez-les sous la plaque pour permettre les réglages en hauteur de l'actuateur.**

Esperar que se consolide el vaciado de hormigón, seguidamente quitar las tuercas "D" y las arandelas "R" faja larga 11x30 y ponerlas debajo de la placa para consentir las regulaciones de altura del actuador.

**Odczekać na utwardzenie wylewu betonowego, a następnie odmontować nakrętki „D” oraz podkładki „R” szerokopasmowe 11x30 i umieścić je pod płytą w celu umożliwienia regulacji wysokości siłownika.**

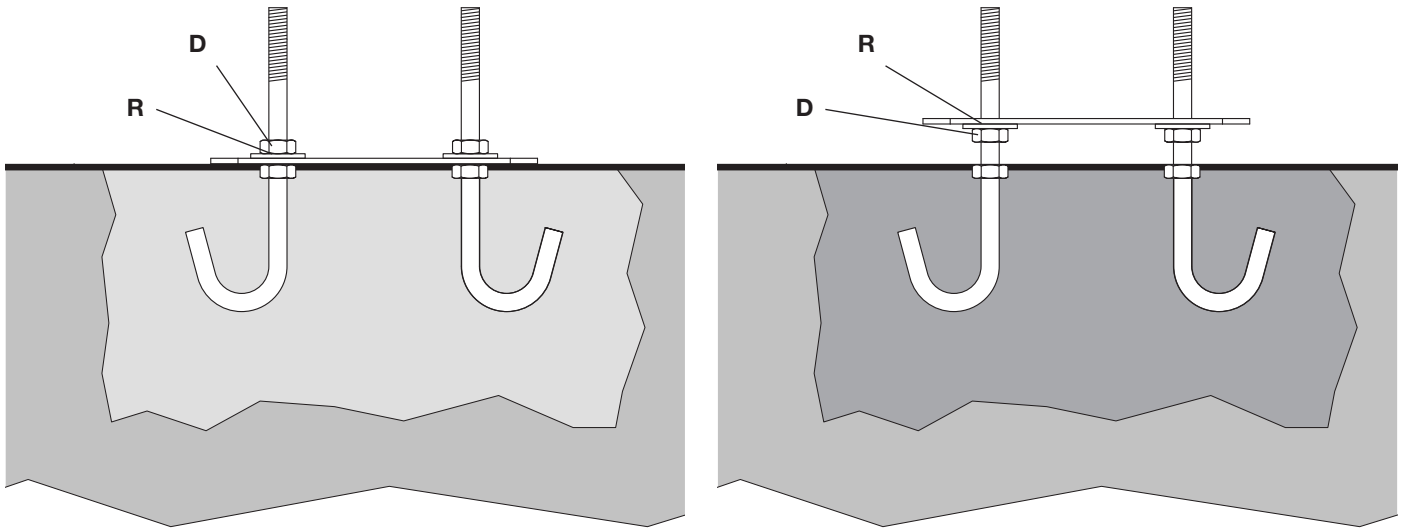
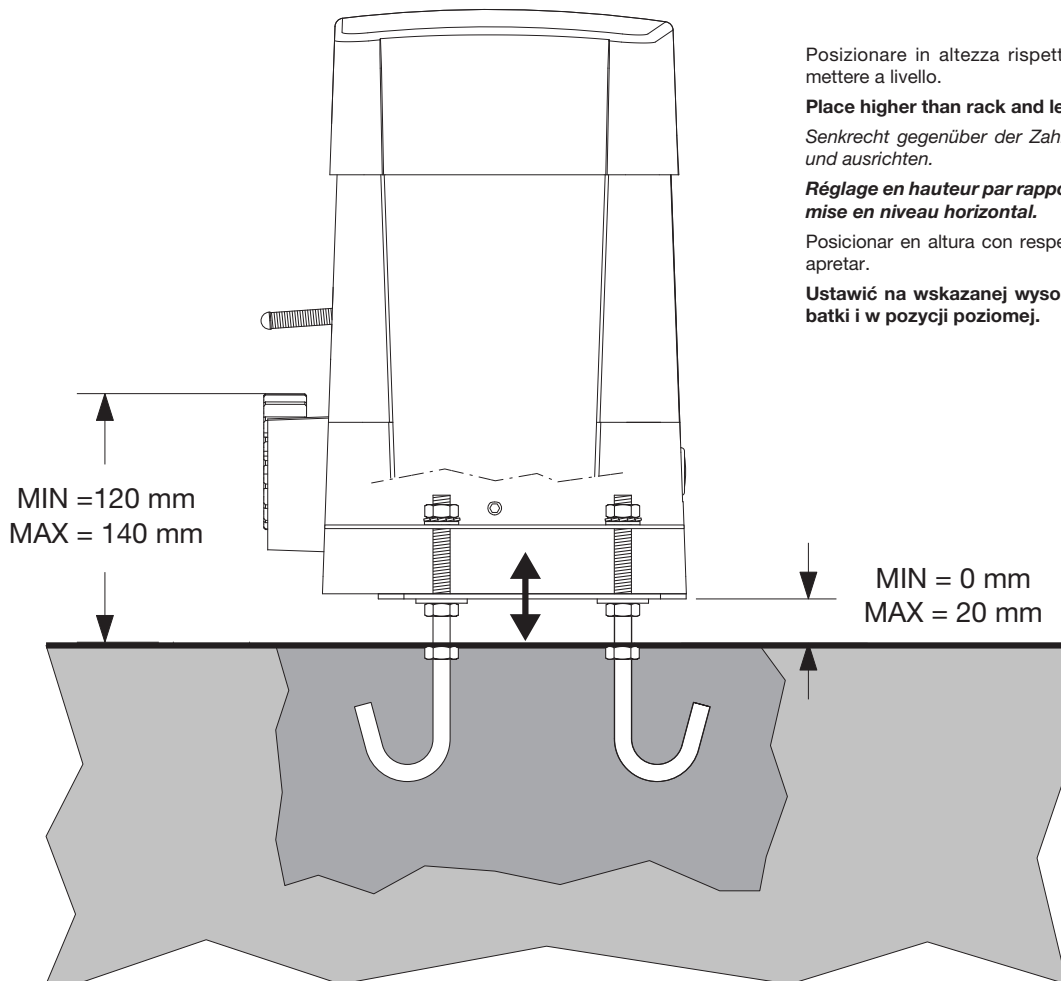

Fig.5



Posizionare in altezza rispetto alla cremagliera e mettere a livello.

**Place higher than rack and level.**

Senkrecht gegenüber der Zahnstange positionieren und ausrichten.

**Réglage en hauteur par rapport à la crémaillère et mise en niveau horizontal.**

Posicionar en altura con respecto a la cremallera y apretar.

**Ustawić na wskazanej wysokości względem zębatki i w pozycji poziomej.**

Fig.6

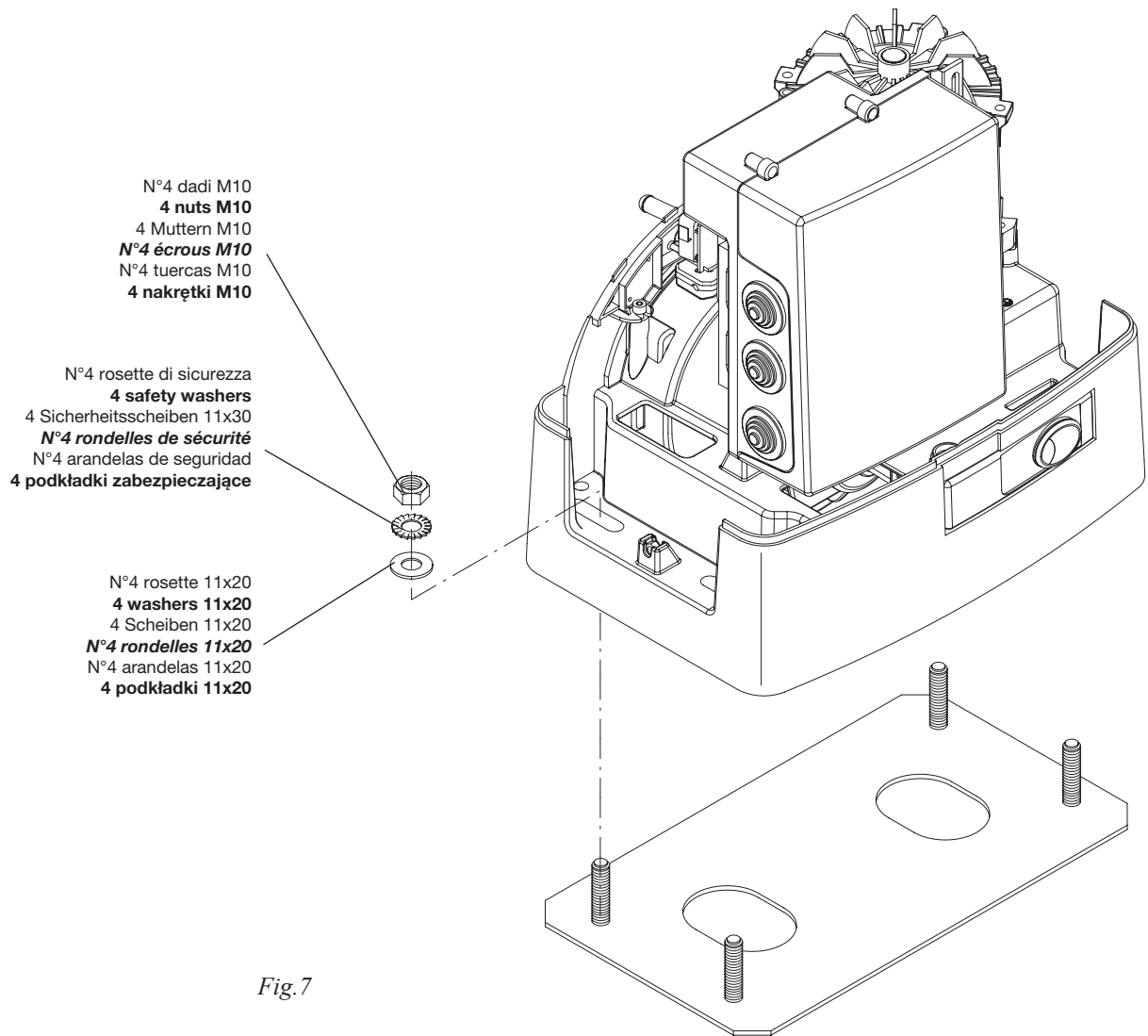
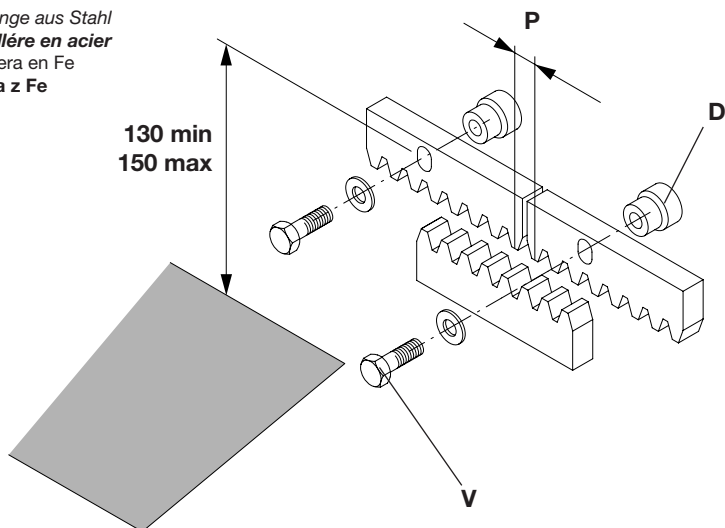

Fig.7

Cremagliera in Fe  
**Fe rack**  
 Zahnstange aus Stahl  
**Cremaillère en acier**  
 Cremallera en Fe  
 Zębatka z Fe



N.B.: Rispettare il passo  
**Important: Keep the pitch**  
 Wichtig: Zahnteilung einhalten

Fig.8

**Important: Respecter le pas**  
 NOTA: Respetar el paso  
**Uwaga: przestrzegać posuwu**

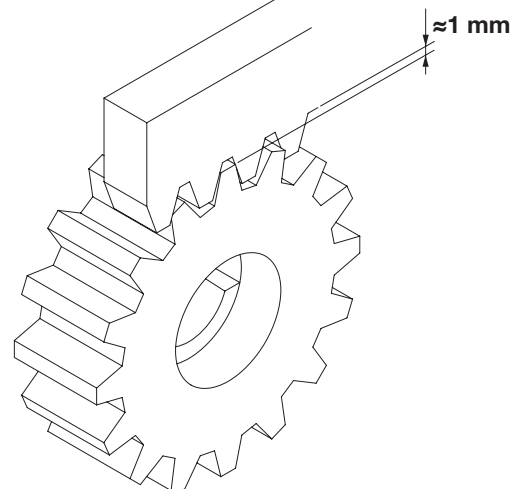
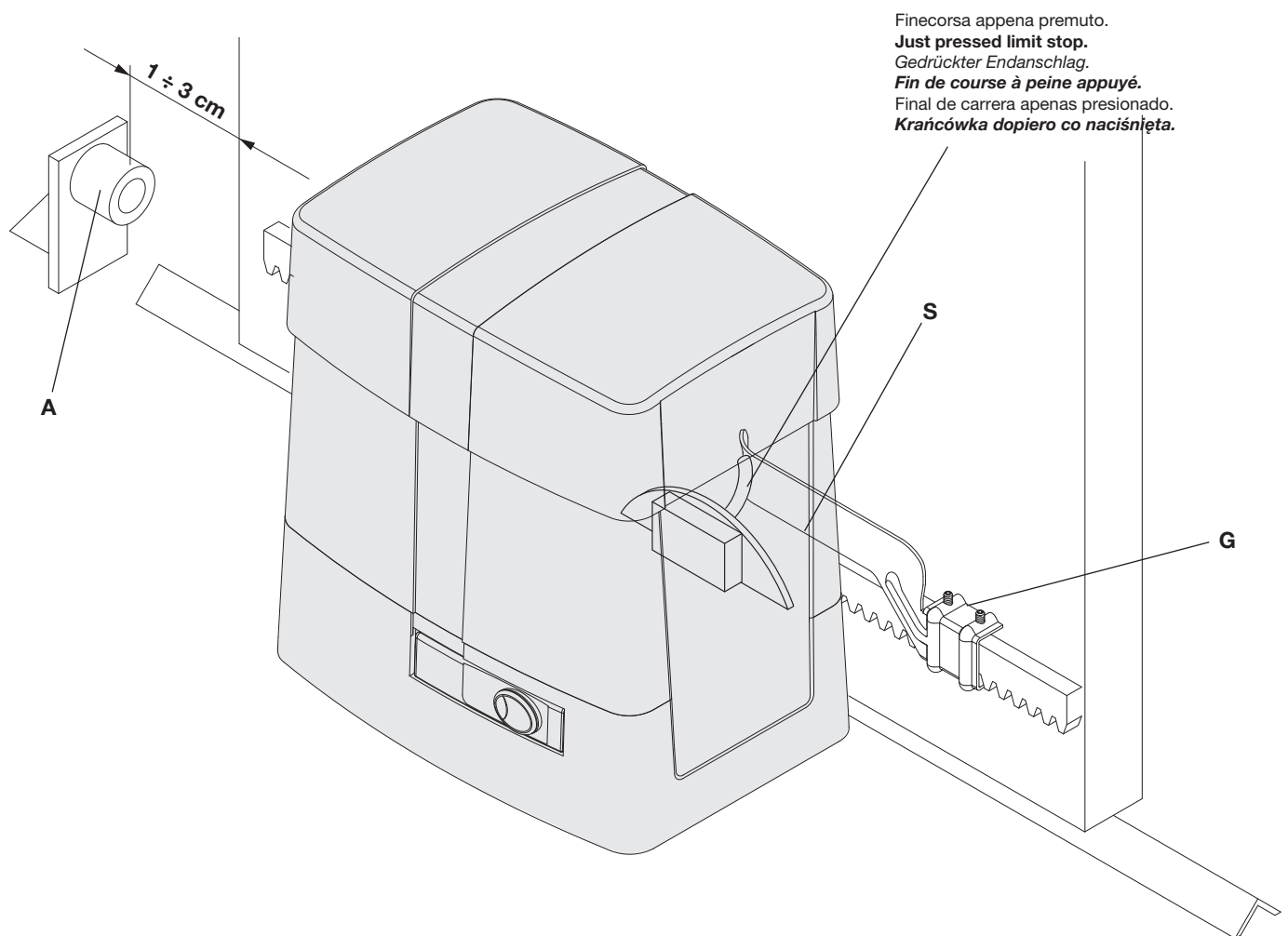
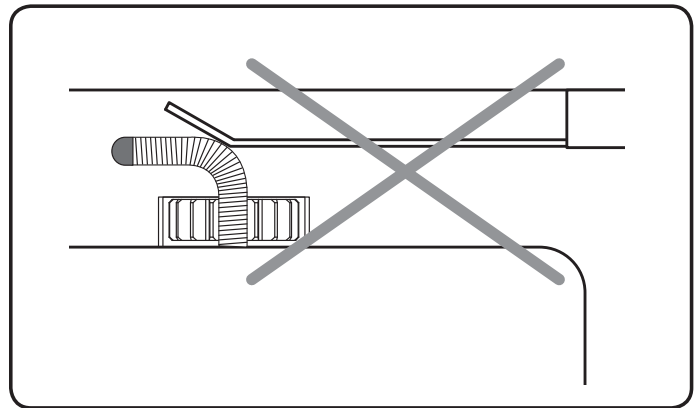
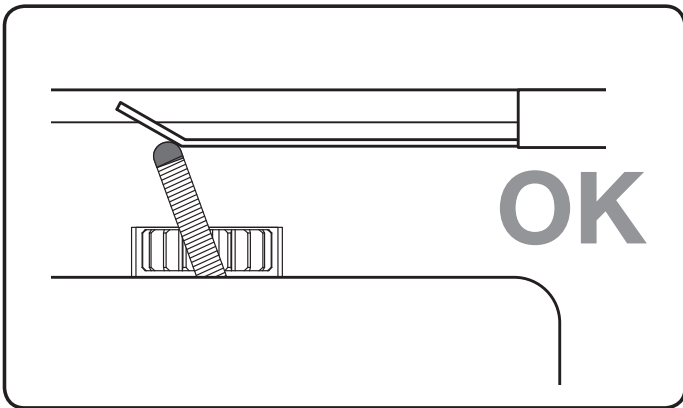

Fig.9



Finecorsa appena premuto.  
**Just pressed limit stop.**  
 Gedrückter Endanschlag.  
**Fin de course à peine appuyé.**  
 Final de carrera apenas presionado.  
**Krańcówka dopiero co naciśnięta.**

N.B.: La staffa del finecorsa deve essere posizionata in modo tale da permettere l'arresto del cancello senza che questo vada a sbattere contro l'arresto meccanico  
**N.b. The limit stop flask must be positioned to ensure that the gate stops without knocking against the mechanical stop.**

Der Endanschlagbügel muß so positioniert werden, daß die Sperre des Gitters ohne das Flattern des Schiebegitters gegen den Endschalter A erfolgen kann.

**N.B. L'étrier de fin de course doit être positionné de façon à pouvoir arrêter le portail, sans qu'il aille bûter sur le fin de course mécanique.**

NOTA: La pletina del final de carrera debe ser colocada de tal forma que permita la parada de la cancela sin que ésta vaya a tocar con el tope mecánico.

**Uwaga: Zaczep krańcówki musi być w pozycji takiej by możliwe było zatrzymanie bramy niedopuszczając do jej zderzenia z zaporą mechaniczną.**

Fig.10

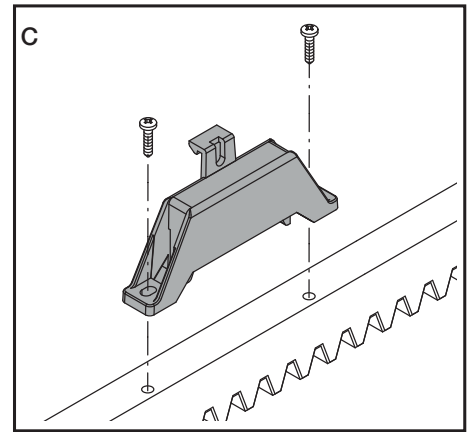
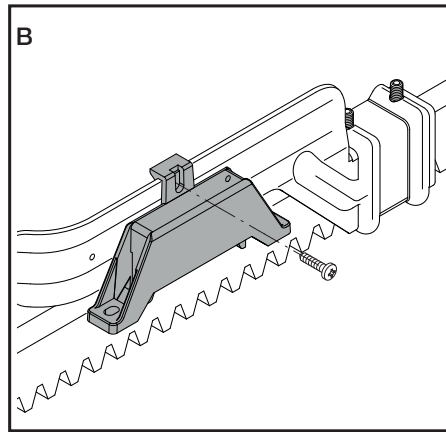
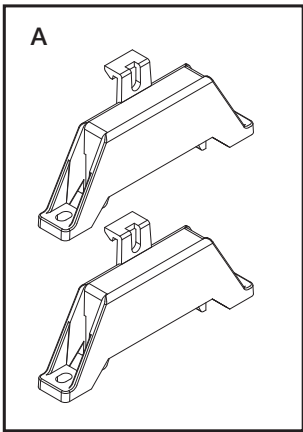

Fig.11

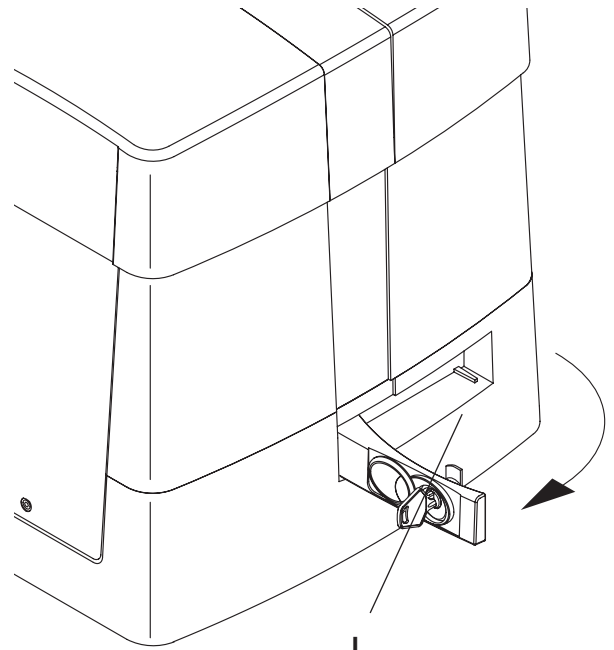
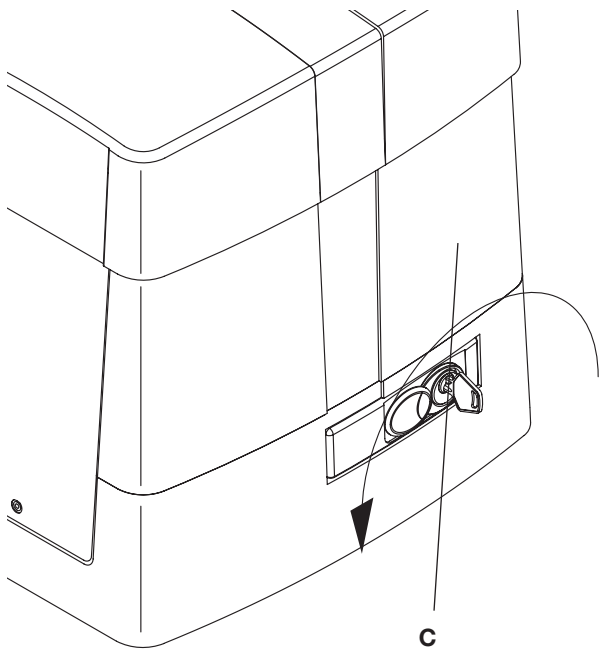
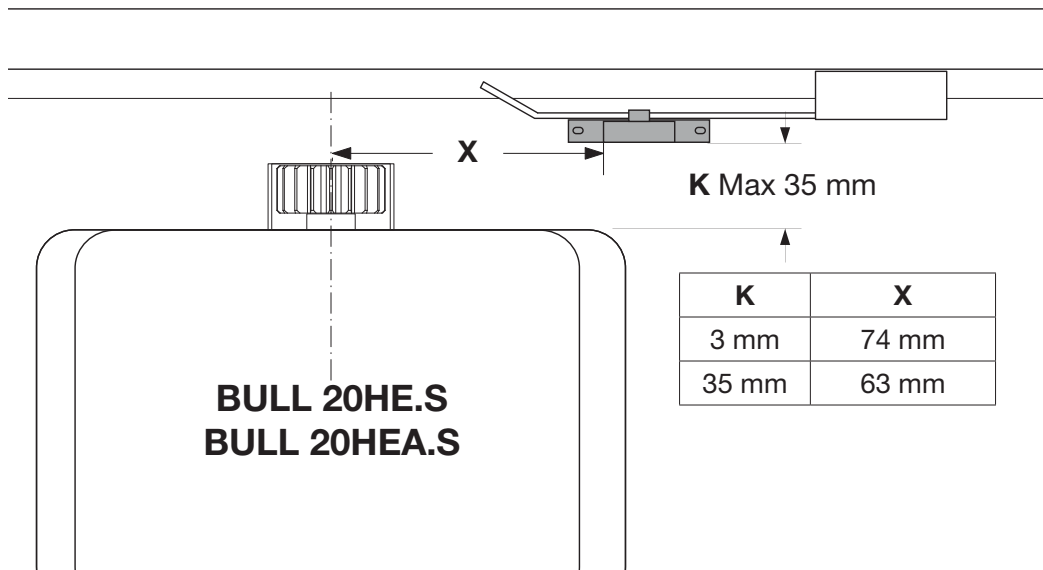
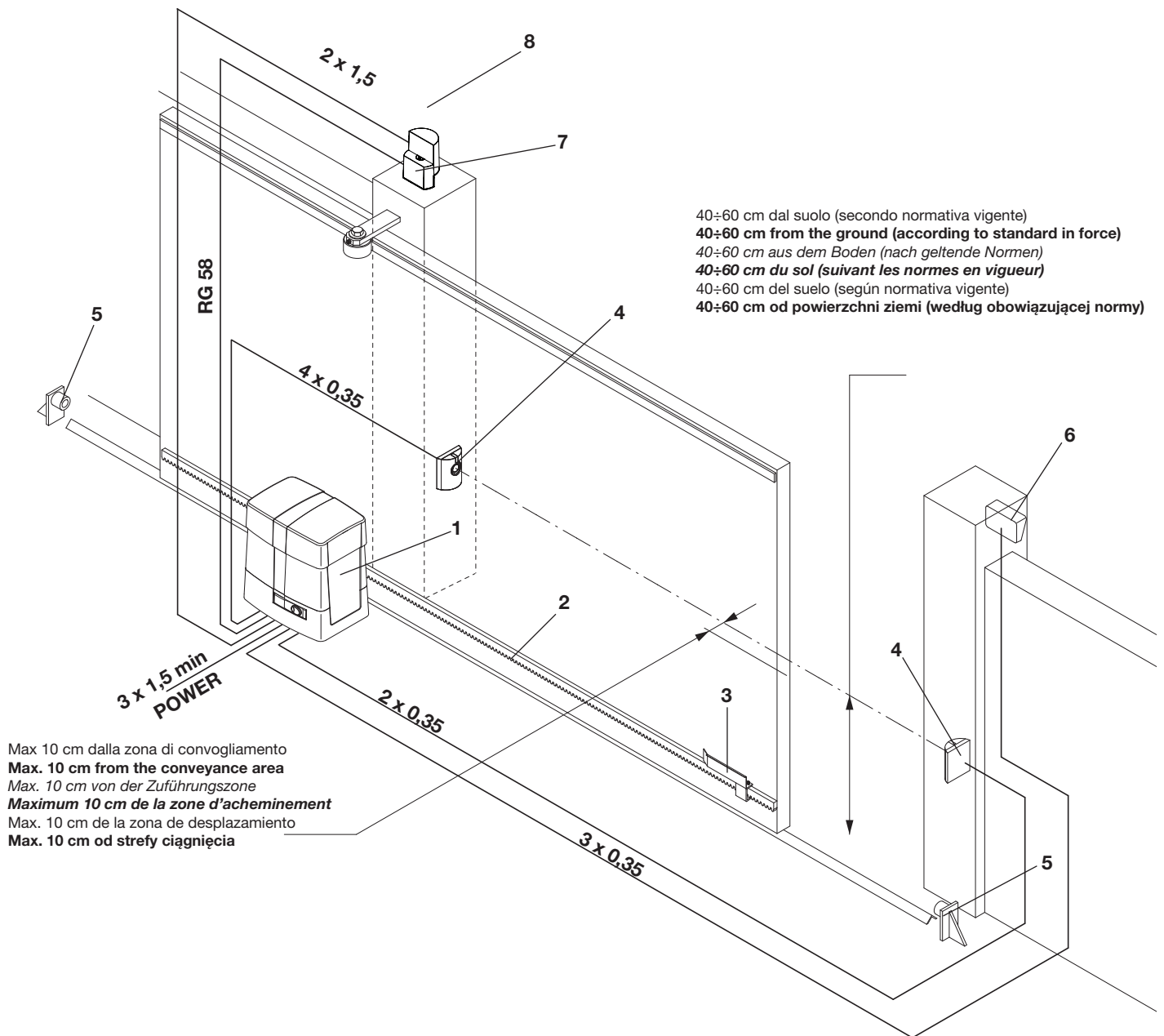

Fig.12





40±60 cm dal suolo (secondo normativa vigente)  
 40±60 cm from the ground (according to standard in force)  
 40±60 cm aus dem Boden (nach geltende Normen)  
 40±60 cm du sol (suivant les normes en vigueur)  
 40±60 cm del suelo (según normativa vigente)  
 40±60 cm od powierzchni ziemi (według obowiązującej normy)

Max 10 cm dalla zona di convogliamento  
 Max. 10 cm from the conveyance area  
 Max. 10 cm von der Zuführungszone  
 Maximum 10 cm de la zone d'acheminement  
 Max. 10 cm de la zona de desplazamiento  
 Max. 10 cm od strefy ciągnięcia

**Legenda:**

- 1 Motoriduttore con centralina incorporata BULL
- 2 Cremagliera RI.M4F/RI.M4Z
- 3 Staffe dei finecorsa
- 4 Fotocellule
- 5 Fermi meccanici
- 6 Selettore a chiave o tastiera digitale
- 7 Lampeggiante
- 8 Antenna

**Legenda:**

- 1 Ratio-motor complete with gear case BULL
- 2 Rack RI.M4F/RI.M4Z
- 3 Limit stop flasks
- 4 Photo-electric cells
- 5 Mechanical stop
- 6 Key or digital keyboard selector
- 7 Blinker
- 8 Antenna

**Zeichenerklärung:**

- 1 Drehzahlminderer mit eingebauter Schaltanlage BULL
- 2 Zahnstange RI.M4F/RI.M4Z
- 3 Endschlagbügel
- 4 Fotozelle
- 5 Mech. Endanschlag
- 6 Schlüssel-Selektor oder Digital-Tastatur
- 7 Blinklicht
- 8 Antenne

**Légende:**

- 1 Motorréducteur avec circuit intégré BULL
- 2 Cremagliera RI.M4F/RI.M4Z
- 3 Etriers de fin de course
- 4 Photocellules
- 5 Bûtee mécanique
- 6 Sélecteur à clef ou à clavier
- 7 Feu clignotant
- 8 Antenne

**Leyenda:**

- 1 Motorreductor con centralita incorporada BULL
- 2 Cremallera RI.M4F/RI.M4Z
- 3 Pletinas de los finales de carrera
- 4 Fotocélulas
- 5 Topes mecánicos
- 6 Selector a llave o teclado digital
- 7 Relampagueador
- 8 Antena

**Objaśnienia:**

- 1 Siłownik z wbudowaną centralką BULL
- 2 Zębatka RI.M4F/RI.M4Z
- 3 Zawieszki krańcowych wyłączników posuwu
- 4 Fotokomórki
- 5 Chwytki mechaniczne
- 6 Przełącznik kluczowy lub panel sterujący
- 7 Światło migające
- 8 Antena

Fig.13



The product shall not be used for purposes or in ways other than those for which the product is intended for and as described in this manual. Incorrect uses can damage the product and cause injuries and damages.  
The company shall not be deemed responsible for the non-compliance with a good manufacture technique of gates as well as for any deformation, which might occur during use.  
Keep this manual for further use.



This manual has been especially written to be use by qualified fitters.  
Installation must be carried out by qualified personnel (professional installer, according to EN 12635), in compliance with Good Practice and current code.  
Make sure that the structure of the gate is suitable for automation.  
The installer must supply all information on the automatic, manual and emergency operation of the automatic system and supply the end user with instructions for use.



Packaging must be kept out of reach of children, as it can be hazardous. For disposal, packaging must be divided the various types of waste (e.g. carton board, polystyrene) in compliance with regulations in force.  
Do not allow children to play with the fixed control devices of the product. Keep the remote controls out of reach of children.  
This product is not to be used by persons (including children) with reduced physical, sensory or mental capacity, or who are unfamiliar with such equipment, unless under the supervision of or following training by persons responsible for their safety.  
Apply all safety devices (photocells, safety edges, etc.) required to keep the area free of impact, crushing, dragging and shearing hazard. Bear in mind the standards and directives in force, Good Practice criteria, intended use, the installation environment, the operating logic of the system and forces generated by the automated system.  
Installation must be carried out using safety devices and controls that meet standards EN 12978 and EN 12453.



An omnipolar switch/section switch with remote contact opening equal to, or higher than 3mm must be provided on the power supply mains.  
Make sure that before wiring an adequate differential switch and an overcurrent protection is provided.  
Pursuant to safety regulations in force, some types of installation require that the gate connection be earthed.  
During installation, maintenance and repair, cut off power supply before accessing to live parts.  
Also disconnect buffer batteries, if any are connected.  
The electrical installation and the operating logic must comply with the regulations in force.  
The leads fed with different voltages must be physically separate, or they must be suitably insulated with additional insulation of at least 1 mm.  
The leads must be secured with an additional fixture near the terminals.  
During installation, maintenance and repair, interrupt the power supply before opening the lid to access the electrical parts  
Check all the connections again before switching on the power.  
The unused N.C. inputs must be bridged.



#### WASTE DISPOSAL

As indicated by the symbol shown, it is forbidden to dispose this product as normal urban waste as some parts might be harmful for environment and human health, if they are disposed of incorrectly. Therefore, the device should be disposed in special collection platforms or given back to the reseller if a new and similar device is purchased. An incorrect disposal of the device will result in fines applied to the user, as provided for by regulations in force.

*Descriptions and figures in this manual are not binding. While leaving the essential characteristics of the product unchanged, the manufacturer reserves the right to modify the same under the technical, design or commercial point of view without necessarily update this manual.*

## 1. General information

For an efficient operation of the sliding automatic mechanism, the gate must have the following features:

- The guide rail and its wheels must be suitable in size and maintained to prevent gate from excessive sliding friction.
- When running, gate must not rock excessively.
- Opening and closing stroke must be regulated by a mechanical limit stop (to safety standard in force).

## 2. General features

Automation with single-phase power supply for sliding gates, available in 2 models:

BULL 20HE for gates with max weight of 2000 Kg with 230 Vac mains power supply

BULL 20HEA for gates with max weight of 2000 Kg with 120 Vac mains power supply

The small and elegant design enbloc BULL consists of an aluminium unit containing the motor and irreversible reduction unit, realized with high-grade materials.

The BULL has a spring-operated limit-switch.

A personalized key emergency release enables manual gate operation in the event of power failure.

Anti-crash safety is ensured by an electronic device (encoder), which detects the presence of any obstacle.

## 3. Installation of the foundation plate

Dimensions of the foundation plate are shown in Fig. 1.

It is essential to keep the distance from the rack, in order to position and remove the actuator once the rack is fitted to the gate leaf.

The types of fittings of the foundation plate are mainly the following:

### 1 Installation without adjustment in height on the already existing base in concrete (Fig.2).

By using the plate as drilling template, drill 4 holes  $\varnothing 10\text{mm}$ , and insert the steel threaded screw anchors,  $\varnothing 10 \times 120\text{mm}$ , similar to those shown in Fig. 2.

Lock the actuator directly to floor, as indicated in Fig.7.

### 2 Installation with adjustment in height on the already existing base in concrete (Fig.3).

By using the plate as drilling template, drill 4 holes, and insert the  $\varnothing 10\text{mm}$  steel screw anchors for threaded bars.

Tighten the 4 threaded bars, M10/120mm, and anchor the screw anchors by tightening the nuts "B" to floor with the corresponding washers.

With reference to Fig. 3, position the foundation plate by means of the adjustment nuts "A". After carrying out the required regulations, position the motor as shown in Fig.6, and lock it, as indicated in Fig.7.

### 3 Installation with adjustment in height on concrete base.

With reference to Fig. 4, fit the stretcher bolts on the foundation plate and provide for a hole of adequate size. Immerse the stretcher bolts in concrete, then remove the nuts "D" and the 11x30, large band washers "R". Move them under the plate to allow for regulations in height of the actuator (Fig. 5).

Carry out the regulations shown in Fig. 6 and lock the motor as indicated in Fig.7.

**CAUTION: apart from the fitting modality used, carefully check that the actuator is steadily positioned and the materials are suited to the intended use.**

## 4. Rack fixing

### Iron rack, 12x30mm.

Position the spacers D by welding or fit them to the gate with screws at 130/150mm height from the centre line of the slot used for fitting to the base on which the foundation plate is to be fixed.

Keep the pitch of teeth between the two parts of the rack; the joining with another piece of rack would make it easier to achieve (see Fig.8)

Secure the rack with the screws V making sure, once the actuator has been installed, that between rack and the drive gear there is always approx. 1mm clearance (see Fig.9); to get this clearance use the slots on the rack.

## 5. Limit stop flask positioning (see Fig.10)

Open manually the gate and leave approximately of  $1 \div 3\text{cm}$ , depending on gate weight, between gate and positive mechanical stop A; tighten the limit stop flask S with the grains G to press the limit stop micro. Repeat the sequence with closing gate.

## 6. How to install the magnets (BULL 20HE.S - 20HEA.S) fig.11

The magnets are housed in special supports (fig.11-"A"). These magnets are to be fitted to the limit switch brackets or the rack and cause the triggering of sensors when they approach them.

Fitting onto the limit switch brackets

The bases are complete with hooking tongue allowing the fitting of the magnets to the limit switch bracket supplied with the operator, as shown in Fig.11-B.

This type of fitting allows to rapidly adjust the position of magnets. After calculating the correct distance, fix the support in the correct position by means of a screw, so as to avert the moving of the bracket.

Fitting onto the rack

As an alternative, the supports can be fitted directly to the rack, by using the slots shown in Fig. 11-C. This fitting mode does not allow for subsequent regulations. It is therefore advised to make some trials with temporarily fitted supports before carrying out the final fitting.

**IMPORTANT:** The correct distance of the magnet with respect to the sensor depends on the installation characteristics. This space cannot be preset and must be adjusted on a trial basis.

The distances regarding the triggering of the sensor (value X) with respect to distance K of 3 and 35 mm, which are shown in Fig. 11 are only indicative.

In any case, distance K must not exceed 35 mm as a higher distance will not allow the triggering of the magnetic sensor.

## 7. Manual operation (see Fig.12)

In the event of power failure or malfunction, to manually operate the gate proceed as follows:

- After inserting the customized key C, turn it anti-clockwise and pull the lever L.
- The geared motor is unlocked and the gate can be moved by hand.
- To return to the normal operating mode, close the lever L again and manually activate the gate until it is geared.

## 8. Wire diagram

For the wire connections of the system and to adjust the operating modes, please refer to the Instruction Manual of the control unit.

**In particular, the anti-crash device (encoder) should be adjusted according to regulations in force.**

Please remember that the device **should be earthed** by means of the appropriate terminal.

# BULL

## User's handbook

### Safety measures

- Do not stand within the gate movement area.
- Children must not play with controls and near the gate.
- In the event of malfunctions, do not attempt to repair the failure but contact the specialised personnel.

### Manual and emergency manoeuvre

In the event of power failure or malfunction, to manually operate the gate proceed as follows:

- After inserting the customized key C, turn it anti-clockwise and pull the lever L.
- The geared motor is unlocked and the gate can be moved by hand.
- To return to the normal operating mode, close the lever L again and manually activate the gate until it is geared.

### Maintenance

- Every month check the good operation of the emergency manual release.
- It is mandatory not to carry out extraordinary maintenance or repairs as accidents may be caused. These operations must be carried out by qualified personnel only.
- The operator is maintenance free but it is necessary to check periodically if the safety devices and the other components of the automation system work properly. Wear and tear of some components could cause dangers.

### Waste disposal

If the product must be dismantled, it must be disposed according to regulations in force regarding the differentiated waste disposal and the recycling of components (metals, plastics, electric cables, etc.). For this operation it is advisable to call your installer or a specialised company.

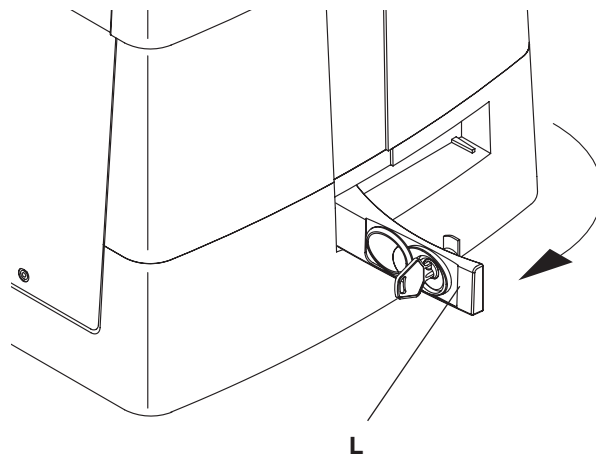
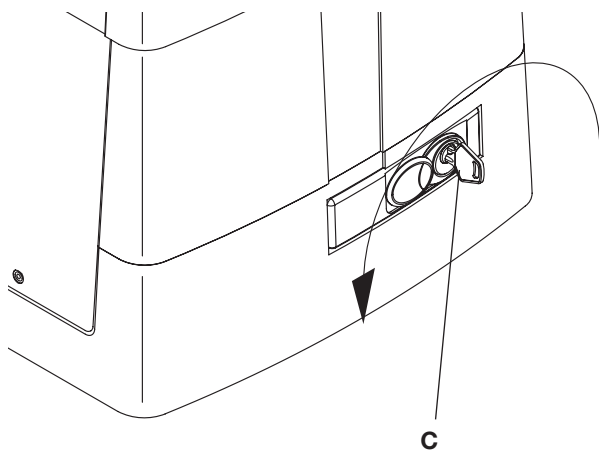

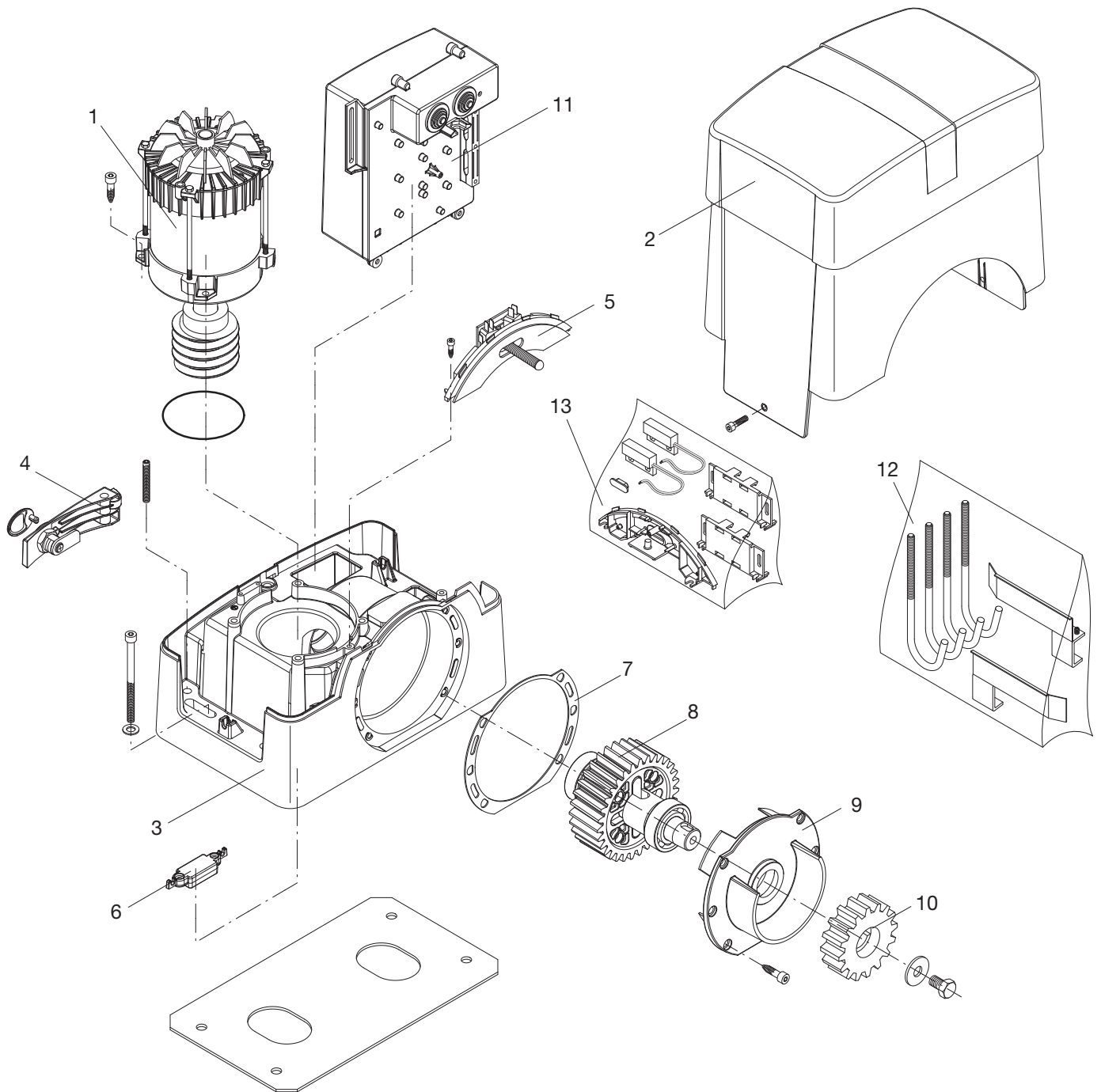

Ref.	BULL 20 HE Code	BULL 20 HEA Code	Note
1	968600981	968600982	
2	9686330		
3	9688319		
4	9686328		
5	9686329		
6	968601570		
7	9686333		
8	9688270		
9	9686335		
10	9686032		
11	968600983	968600984	
12	9686337		
13	9688102		BULL_S

## Dichiarazione CE di Conformità

Dichiarazione in accordo alle Direttive 2004/108/CE(EMC); 2006/95/CE(LVD)

Fabbricante: **Automatismi Benincà SpA**

Indirizzo: **Via Capitello, 45 - 36066 Sandrigo (VI) - Italia**

Dichiara che il prodotto:

**Attuatore elettromeccanico per cancelli scorrevoli modello:**

**BULL 20HE- 20HEA)**

è conforme alle condizioni delle seguenti Direttive CE:

- **DIRETTIVA 2004/108/CE DEL PARLAMENTO EUROPEO E DEL CONSIGLIO** del 15 dicembre 2004 concernente il ravvicinamento delle legislazioni degli Stati membri relative alla compatibilità elettromagnetica e che abroga la direttiva 89/336/CEE, secondo le seguenti norme armonizzate: EN 61000-6-2:2005, EN 61000-6-3:2007.
- **DIRETTIVA 2006/95/CE DEL PARLAMENTO EUROPEO E DEL CONSIGLIO** del 12 dicembre 2006 concernente il ravvicinamento delle legislazioni degli Stati membri relative al materiale elettrico destinato ad essere adoperato entro taluni limiti di tensione, secondo le seguenti norme armonizzate: EN 60335-1:2002 + A1:2004 + A11:2004 + A12:2006 + A2:2006 + A13:2008; EN 60335-2-103:2003.
- **DIRETTIVA 2006/42/CE DEL PARLAMENTO EUROPEO E DEL CONSIGLIO** del 17 maggio 2006 relativa alle macchine e che modifica la direttiva 95/16/CE, rispettando i requisiti per le “quasi macchine”, secondo la seguente norma: EN13241-1:2003.
- **Automatismi Benincà SpA** dichiara, inoltre, che la documentazione tecnica pertinente è stata compilata in conformità all’allegato VII B della direttiva 2006/42/CE e che sono stati rispettati i seguenti requisiti essenziali: 1.1.1 - 1.1.2 - 1.1.3 - 1.1.5 - 1.2.1 - 1.2.3 - 1.2.6 - 1.3.1 - 1.3.2 - 1.3.3 - 1.3.4 - 1.3.7 - 1.3.9 - 1.5.1 - 1.5.2 - 1.5.4 - 1.5.5 - 1.5.6 - 1.5.7 - 1.5.8 - 1.5.10 - 1.5.11 - 1.5.13 - 1.6.1 - 1.6.2 - 1.6.4 - 1.7.2 - 1.7.4 - 1.7.4.1 - 1.7.4.2 - 1.7.4.3.
- Il produttore si impegna a trasmettere alle autorità nazionali, in risposta ad una motivata richiesta, le informazioni pertinenti sulla “quasi macchina”. L’impegno comprende le modalità di trasmissione e lascia impregiudicati i diritti di proprietà intellettuale del fabbricante della “quasi macchina”.
- Si comunica che la “quasi macchina” non deve essere messa in servizio finché la macchina finale in cui deve essere incorporata non è stata dichiarata conforme, se del caso, alle disposizioni della direttiva 2006/42/CE.
- Inoltre il prodotto, limitatamente alle parti applicabili, risulta conforme alle seguenti norme: EN 12445:2002, EN 12453:2002, EN 12978:2003.

Benincà Luigi, Responsabile legale.

Sandrigo, 18/04/2016.

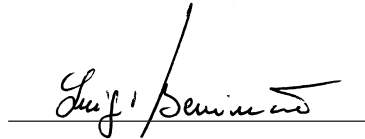

## EC Declaration of Conformity

Directive 2004/108/EC(EMC); 2006/95/EC (LVD)

Manufacturer: **Automatismi Benincà SpA.**

Address: **Via Capitello, 45 - 36066 Sandrigo (VI) – Italy**

It is hereby stated that the product

**automatic system for sliding gates**

**BULL 20HE- 20HEA)**

is compliant with provisions set forth in the following EC Directives:

- **DIRECTIVE 2004/108/EC OF THE EUROPEAN PARLIAMENT AND OF THE COUNCIL** of 15 December 2004, on the harmonisation of the laws of Member States relating to electromagnetic compatibility and which cancels Directive 89/336/EEC, according to the following harmonised regulations: EN 61000-6-2:2005, EN 61000-6-3:2007.
- **DIRECTIVE 2006/95/EC OF THE EUROPEAN PARLIAMENT AND OF THE COUNCIL** of 12 December 2006, on the harmonisation of the laws of Member States relating to electrical equipment designed for use with certain voltage limits, according to the following harmonised regulations: EN 60335-1:2002 + A1:2004 + A11:2004 + A12:2006 + A2:2006 + A13:2008; EN 60335-2-103:2003.
- **DIRECTIVE 2006/42/EC OF THE EUROPEAN PARLIAMENT AND OF THE COUNCIL** of 17 May 2006, on machinery, which amends Directive 95/16/EC, and complies with the requisites for the “partly completed machinery (almost machinery)” set forth in the EN13241-1:2003 regulation.
- Moreover, **Automatismi Benincà SpA** declares that the pertaining technical documentation has been drawn up in compliance with Attachment VII B of the 2006/42/ EC Directive and that the following requirements have been complied with: 1.1.1 - 1.1.2 - 1.1.3 - 1.1.5 - 1.2.1 - 1.2.3 - 1.2.6 - 1.3.1 - 1.3.2 - 1.3.3 - 1.3.4 - 1.3.7 - 1.3.9 - 1.5.1 - 1.5.2 - 1.5.4 - 1.5.5 - 1.5.6 - 1.5.7 - 1.5.8 - 1.5.10 - 1.5.11 - 1.5.13 - 1.6.1 - 1.6.2 - 1.6.4 - 1.7.2 - 1.7.4 - 1.7.4.1 - 1.7.4.2 - 1.7.4.3.
- The manufacturer undertakes that information on the “partly completed machinery” will be sent to domestic authorities. Transmission ways are also included in the undertaking, and the Manufacturer’s intellectual property rights of the “almost machinery” are respected.
- It is highlighted that commissioning of the “partly completed machinery” shall not be provided until the final machinery, in which it should be incorporated, is declared compliant, if applicable, with provisions set forth in the Directive 2006/42/EC on Machinery.
- Moreover, the product, as applicable, is compliant with the following regulations: EN 12445:2002, EN 12453:2002, EN 12978:2003.

Benincà Luigi, Legal Officer.

Sandrigo, 18 April 2016.

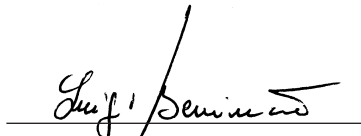

**BENINCA<sup>®</sup>**

**AUTOMATISMI BENINCÀ** SpA - Via Capitello, 45 - 36066 Sandrigo (VI) - Tel. 0444 751030 r.a. - Fax 0444 759728

---